

QUICK CHANGE DOVETAIL CLAMP DETAILS FOR INTERCHANGEABLE PROFILED PART CLAMPS

HEAVY DUTY ROLLER BED WITH 800LB/ROLLER CAPACITY (MAX CAP 2000LBS)

WELDED STEEL FLOOR BASE WITH MACHINE LEVELERS AND THRU HOLE LAG PROVISIONS

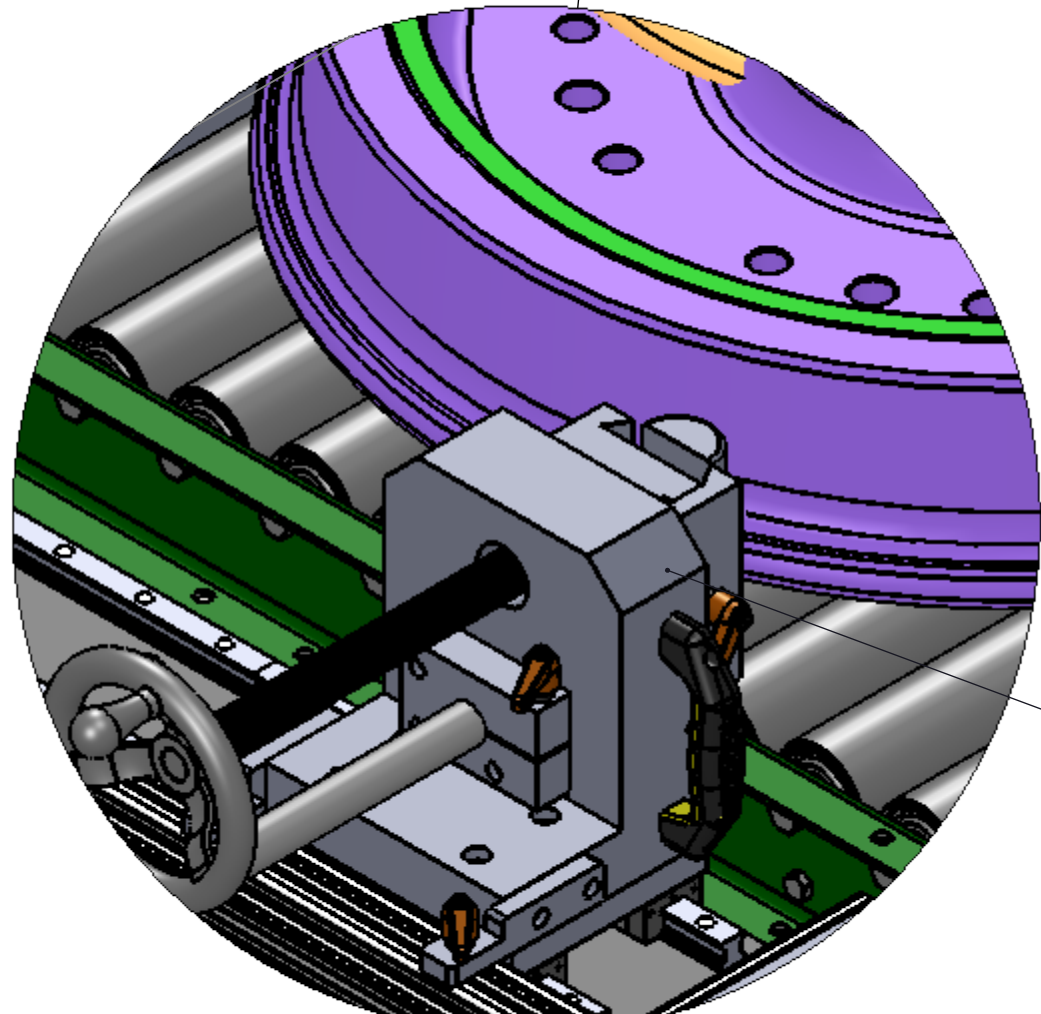
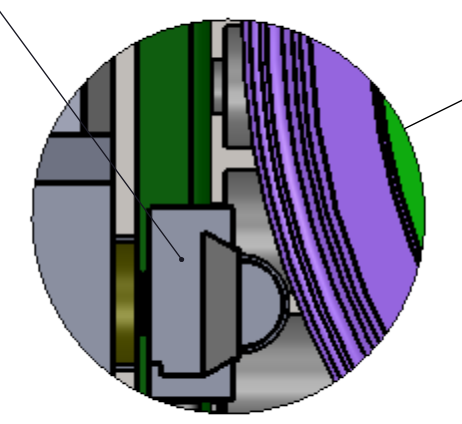

ADJUSTABLE CLAMP/CROWDING MECHANISM FOR VARIOUS PARTS

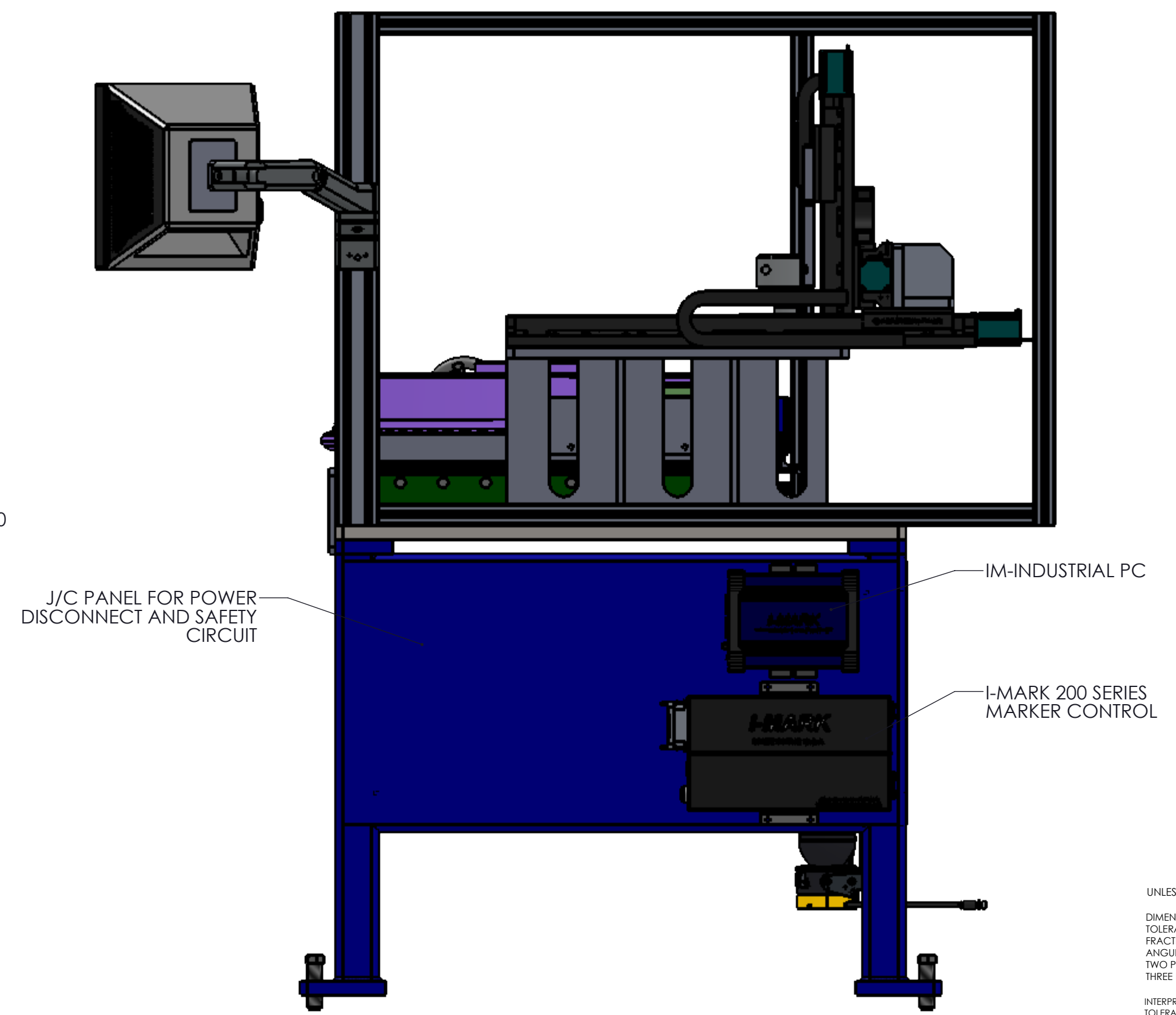
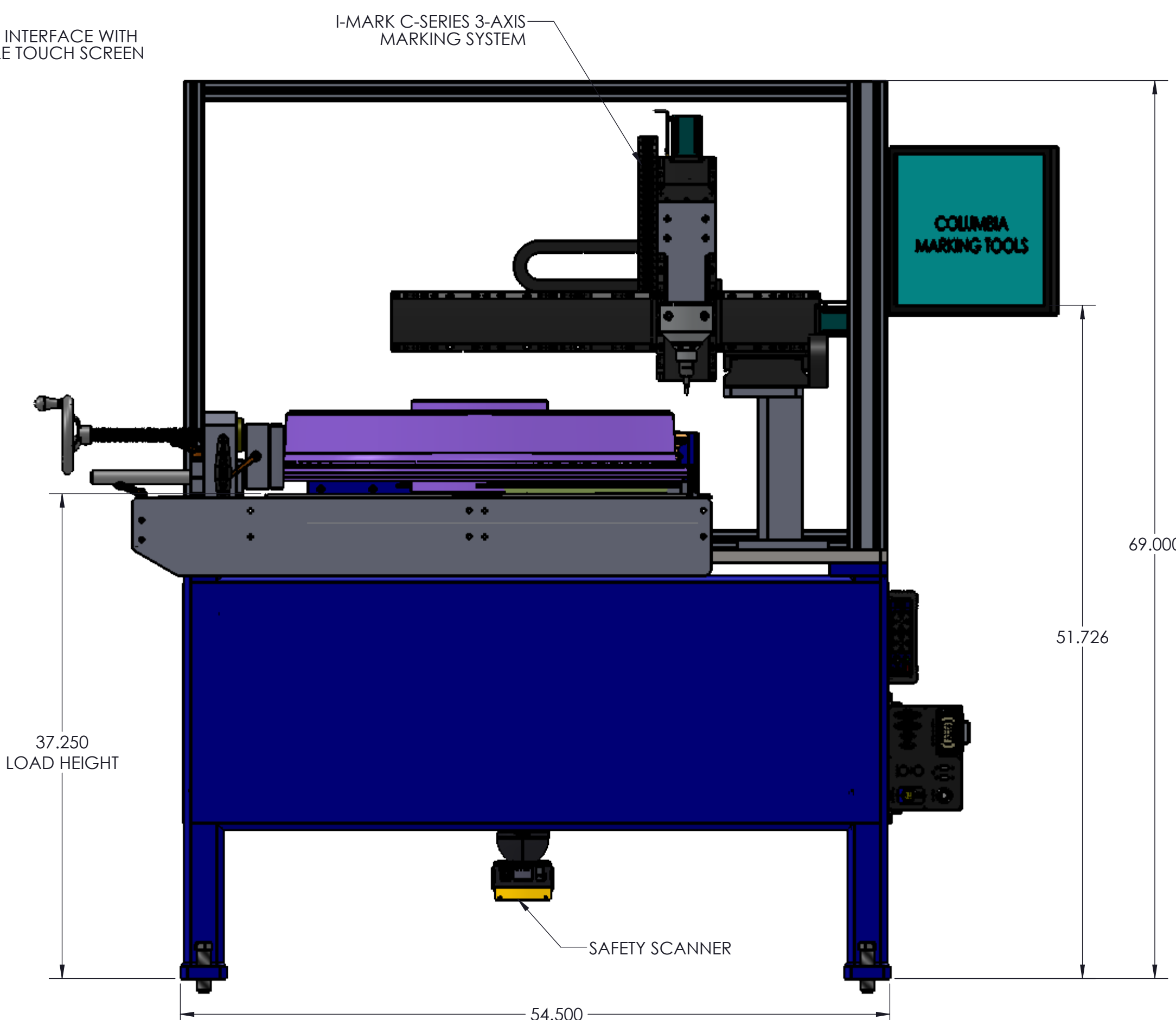
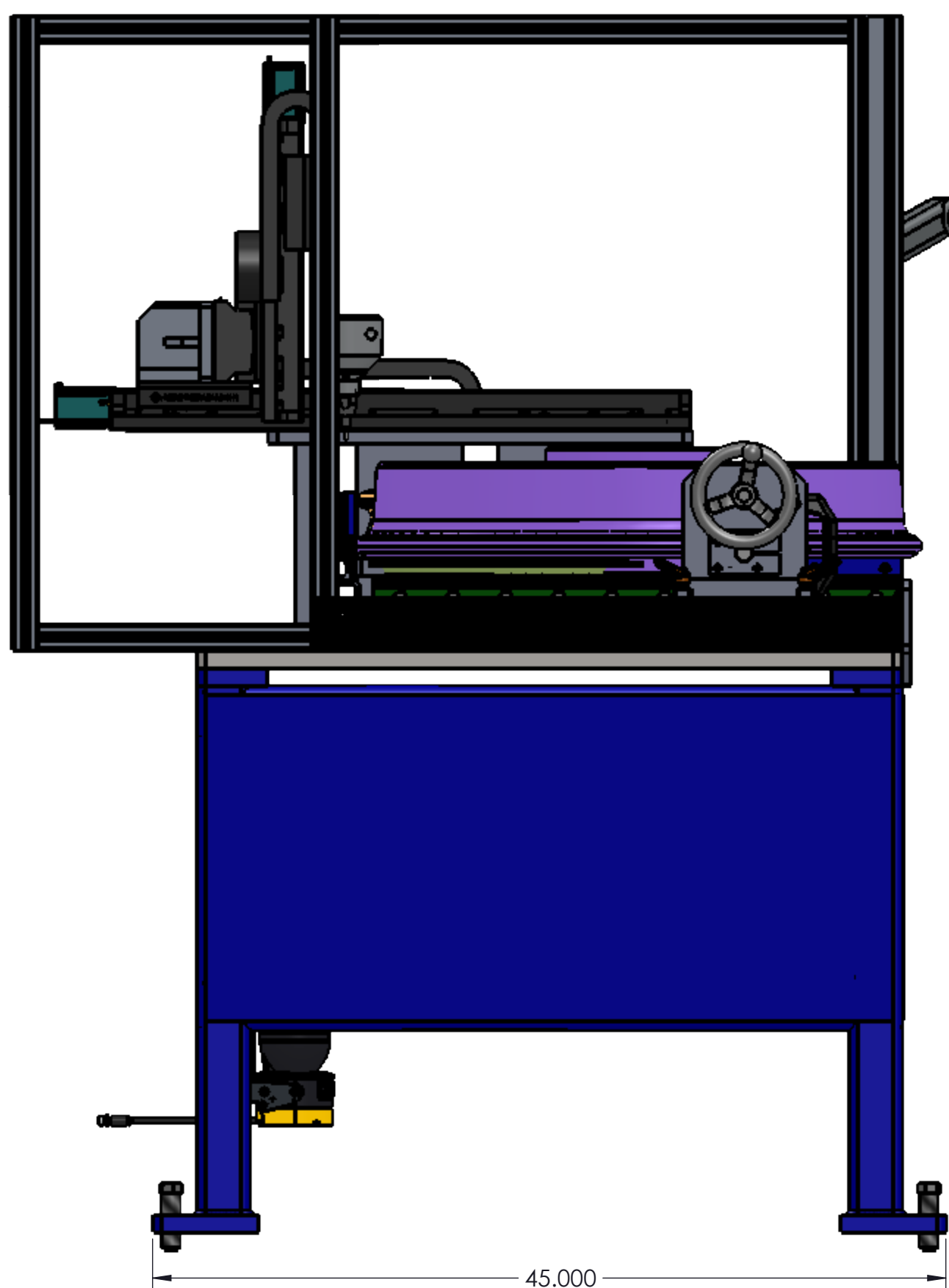
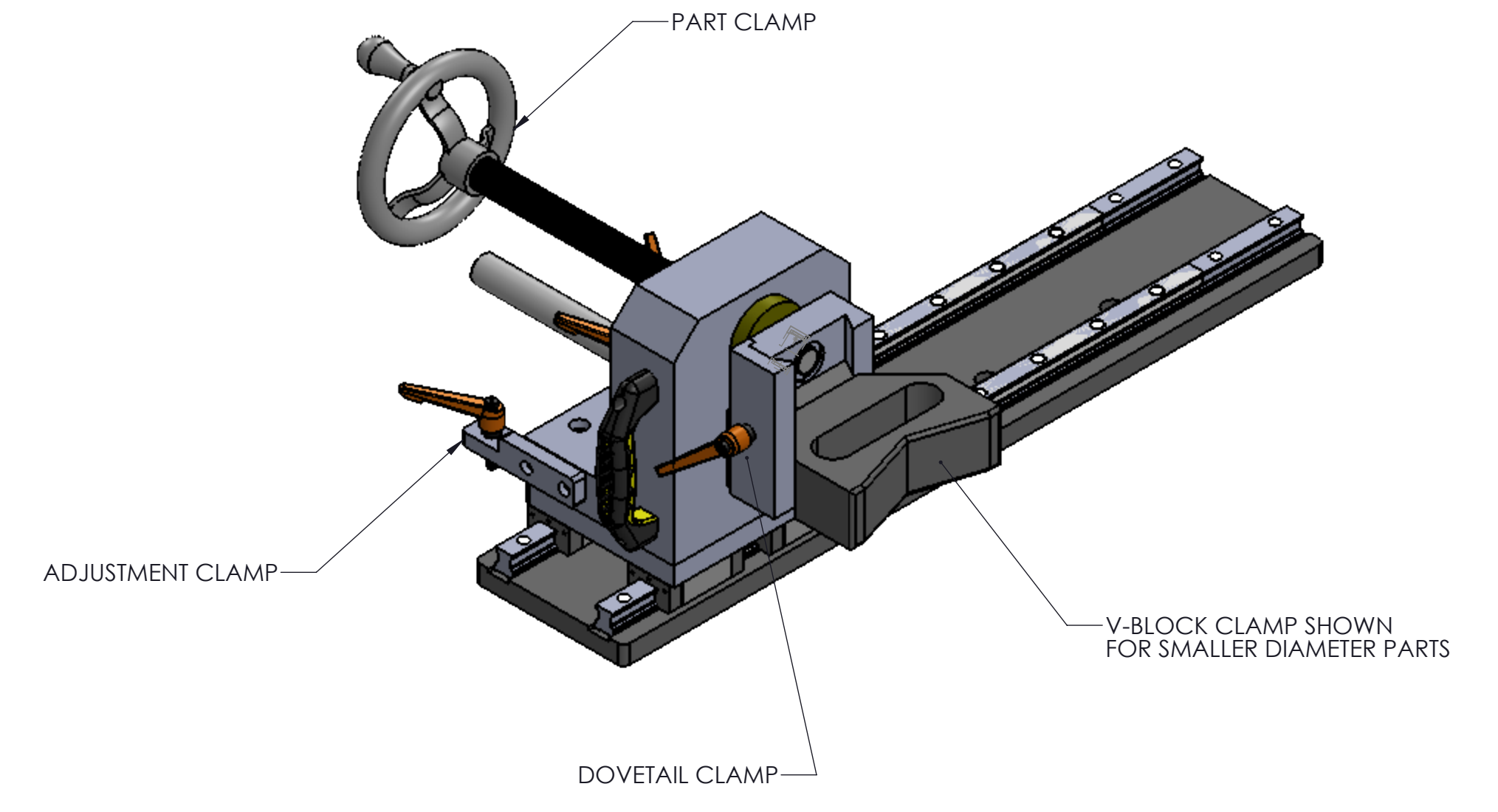
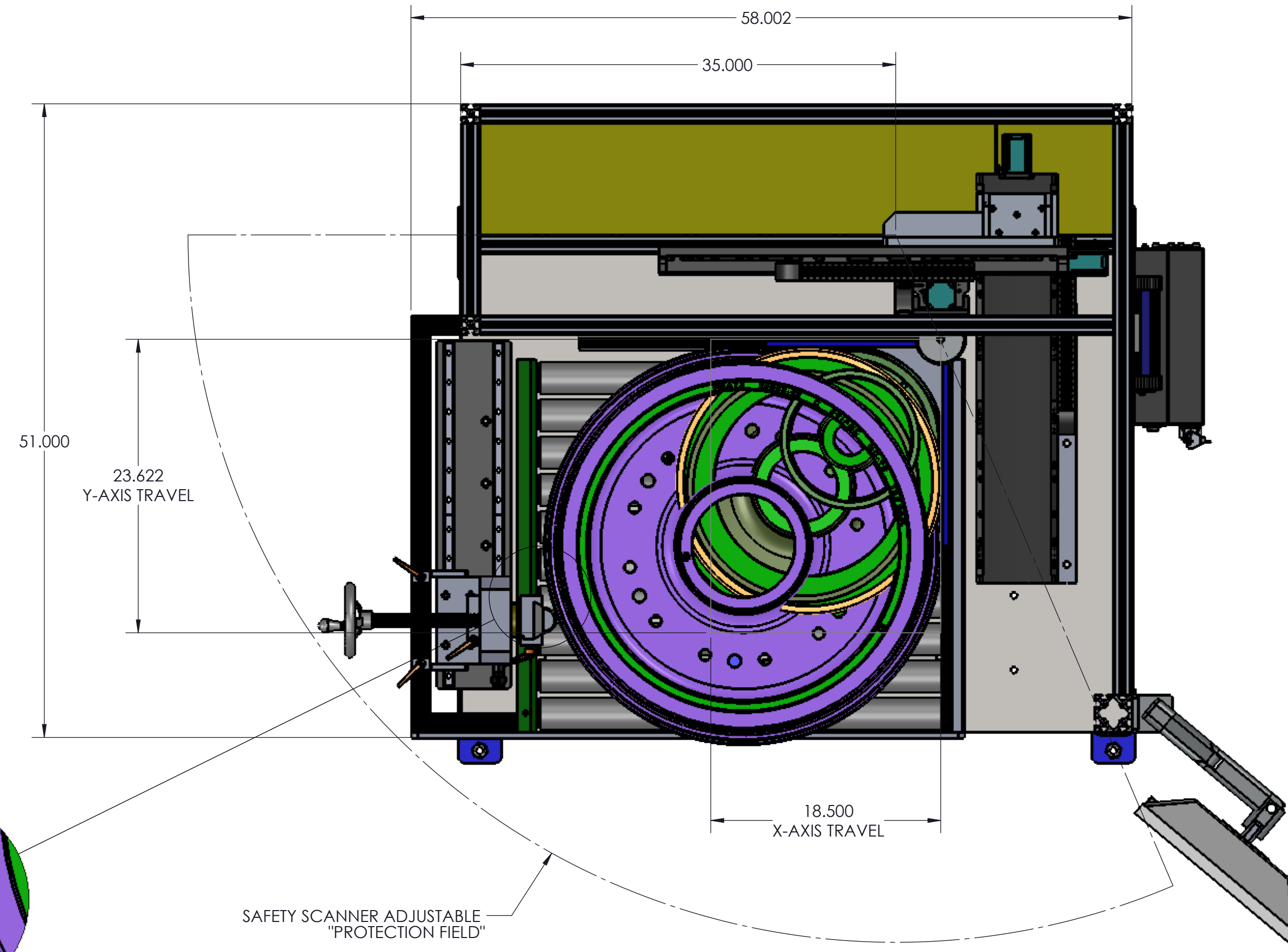

UNLESS OTHERWISE SPECIFIED:  
 DIMENSIONS ARE IN INCHES  
 TOLERANCE: FRACTIONAL: MACH 1 ± THREE PLACE DECIMAL ±  
 ANGULAR: MACH 1 ± TWO PLACE DECIMAL ±  
 INTERPRET GEOMETRIC TOLERANCING PER: ASME Y14.5-2009  
 FINISH: PER PART OR AS A WHOLE WITHOUT THE WRITTEN PERMISSION OF COLUMBIA MARKING TOOLS IS PROHIBITED.

DATE: 11/20/09  
 CHECKED: AJH  
 ENG APPR: AJH  
 MFG APPR: G.A.

NAME: AJH  
 TITLE: ENGINEER

PROPERTY AND CONFIDENTIAL: THE INFORMATION CONTAINED IN THIS DRAWING IS THE SOLE PROPERTY OF COLUMBIA MARKING TOOLS. ANY REPRODUCTION IN PART OR AS A WHOLE WITHOUT THE WRITTEN PERMISSION OF COLUMBIA MARKING TOOLS IS PROHIBITED.

SCALE: 1:10 WEIGHT: 1

REV: 1

IMC-LARGE-1

IMC-LARGE-1

SHEET 1 OF 1