

UNLESS OTHERWISE SPECIFIED:		NAME	DATE	 <small>COLUMBIA MARKING TOOLS 27430 LUCKING DRIVE CHESTERFIELD, MI 48070</small>
DIMENSIONS ARE IN INCHES		DRAWN	AJH	
TOLERANCES:		CHECKED		
FRACTIONAL ±		ENG APPR.		
ANGULAR MATCH ±		MFG APPR.		
BEND ±				
TWO PLACE DECIMAL ±				
THREE PLACE DECIMAL ±				
MATERIAL		Q.A.		
INTERPRET GEOMETRIC TOLERANCING PER:		<small>PROPRIETARY AND CONFIDENTIAL THE INFORMATION CONTAINED IN THIS DRAWING IS THE SOLE PROPERTY OF COLUMBIA MARKING TOOLS. ANY REPRODUCTION IN PART OR AS A WHOLE WITHOUT THE WRITTEN PERMISSION OF COLUMBIA MARKING TOOLS IS PROHIBITED.</small>		
FINISH		<small>SIZE DWG. NO. REV</small> <b>D LE24-A001m01</b>		
		<small>SCALE: 1:4 WEIGHT: SHEET 1 OF 2</small>		

# LE16HD-SERIES LASER ENCLOSURE INCLUDES BASE

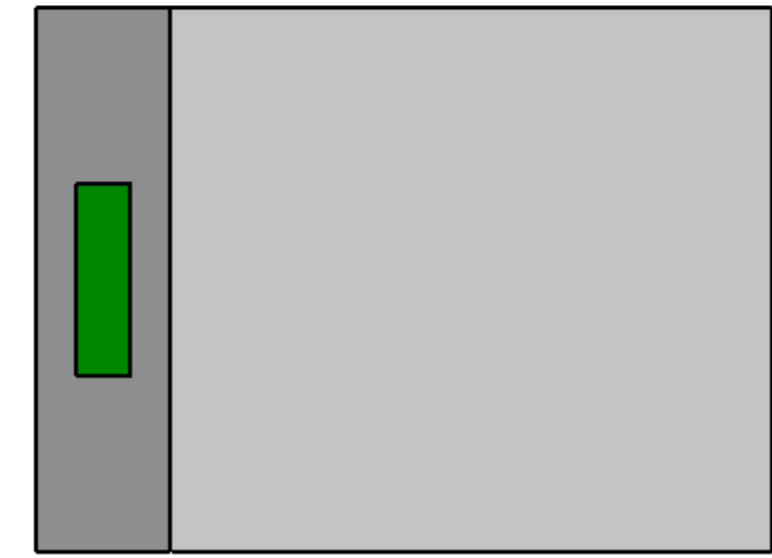
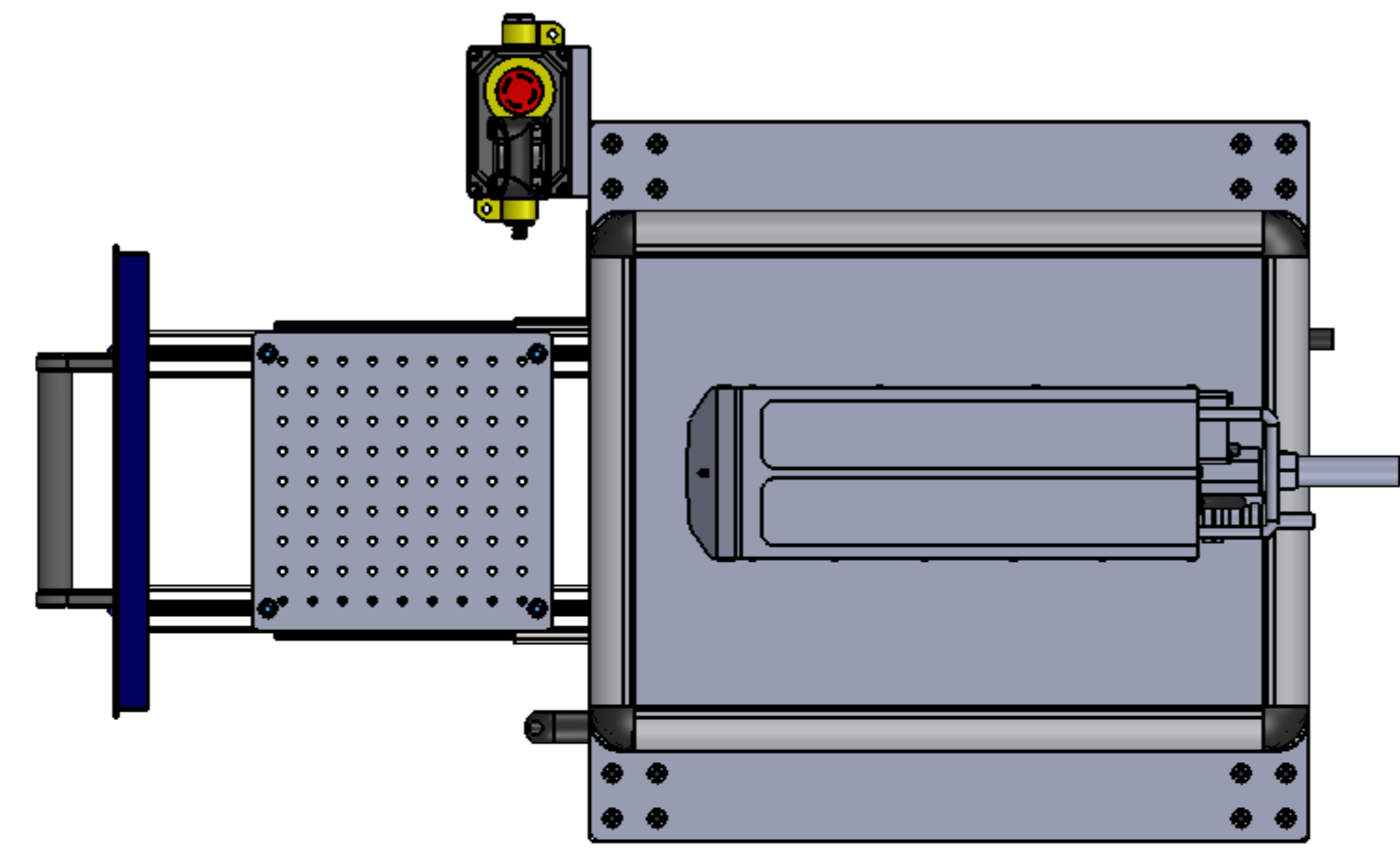

SHOWN WITH LE16HD SERIES CABINET

OPTIONAL CYCLE START WITH E-STOP

MOUNTING FOR LASER CONTROL

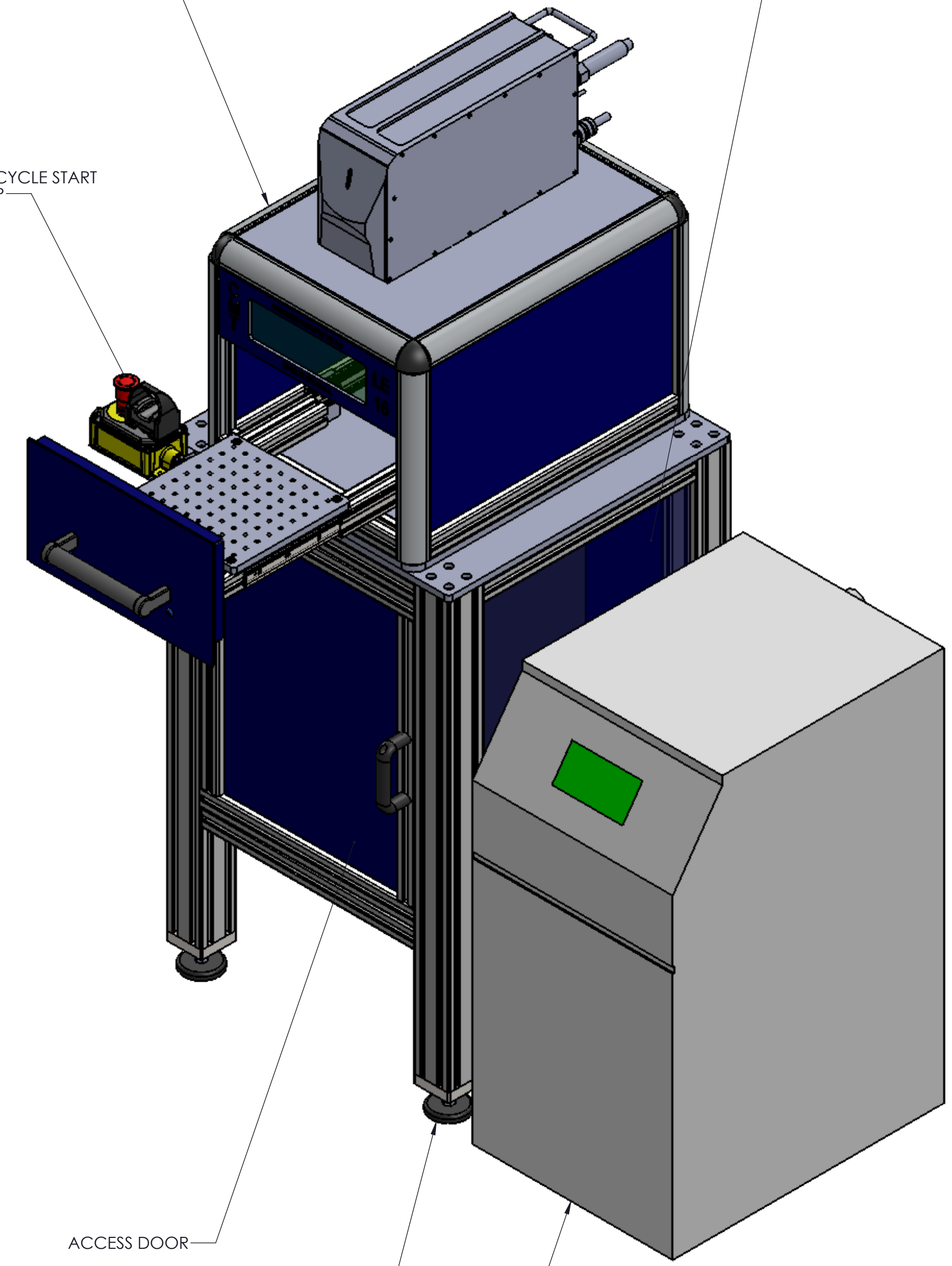

ACCESS DOOR

HEAVY DUTY ADJUSTABLE LEVELING FEET

OPTIONAL FUME EXTRACTION SYSTEM

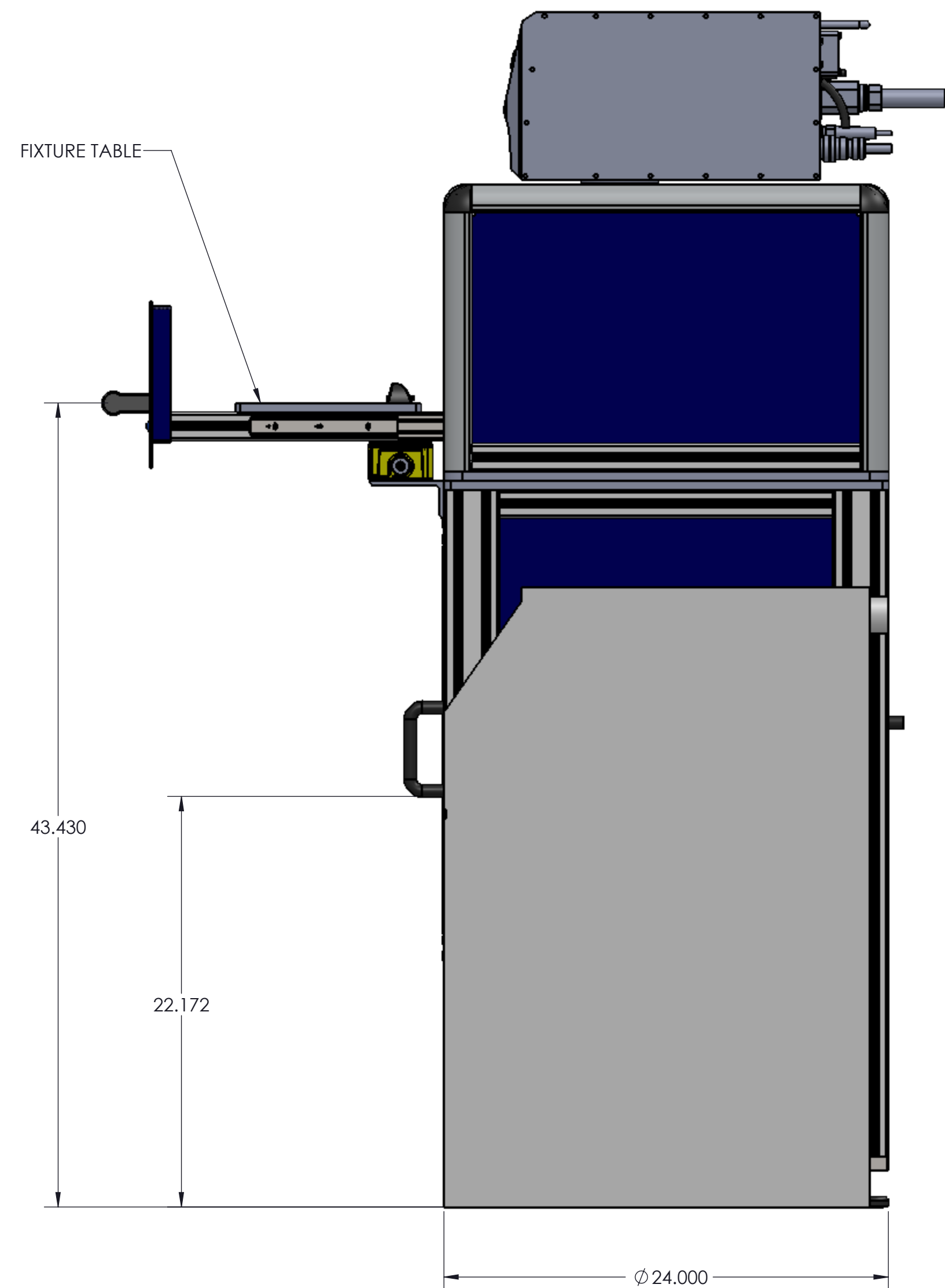
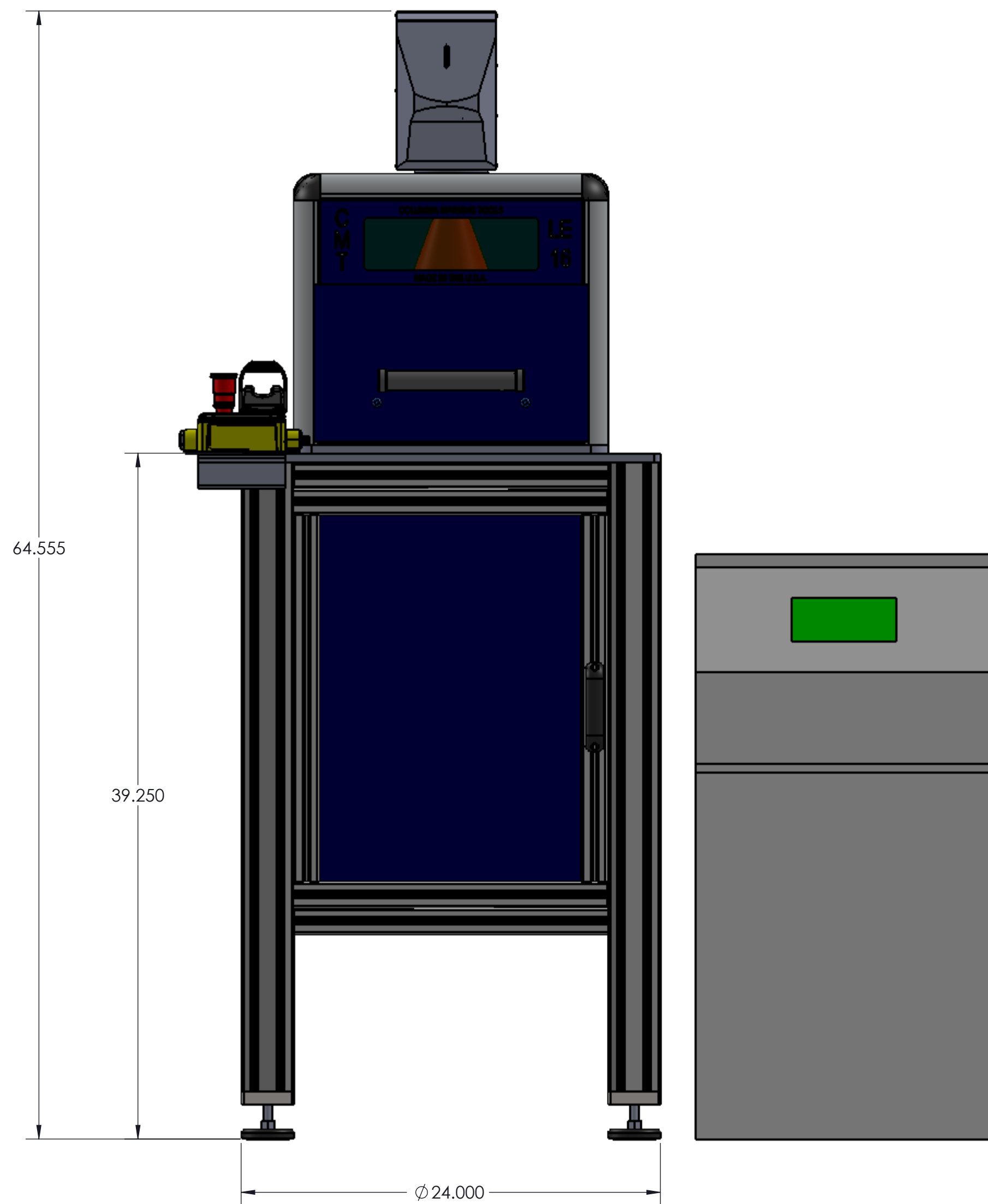

UNLESS OTHERWISE SPECIFIED:		NAME	DATE	
DIMENSIONS ARE IN INCHES	TOLERANCES:	DRAWN	AJH	05/28/15
FRACTIONAL ±	ANGULAR: MACH ±	CHECKED		
TWO PLACE DECIMAL ±	BEND ±	ENG APPR.		
THREE PLACE DECIMAL ±		MFG APPR.		
		Q.A.		
INTERPRET GEOMETRIC TOLERANCING PER:		<b>PROPRIETARY AND CONFIDENTIAL</b> THE INFORMATION CONTAINED IN THIS DRAWING IS THE SOLE PROPERTY OF COLUMBIA MARKING TOOLS. ANY REPRODUCTION IN PART OR AS A WHOLE WITHOUT THE WRITTEN PERMISSION OF COLUMBIA MARKING TOOLS IS PROHIBITED.		
FINISH		SIZE	DWG. NO.	REV
		D	LE16-A001m01	
		SCALE: 1:4	WEIGHT:	SHEET 2 OF 2

REV D LE16-A001m01