

AIR KNIFE FOR PART BLOW OFF

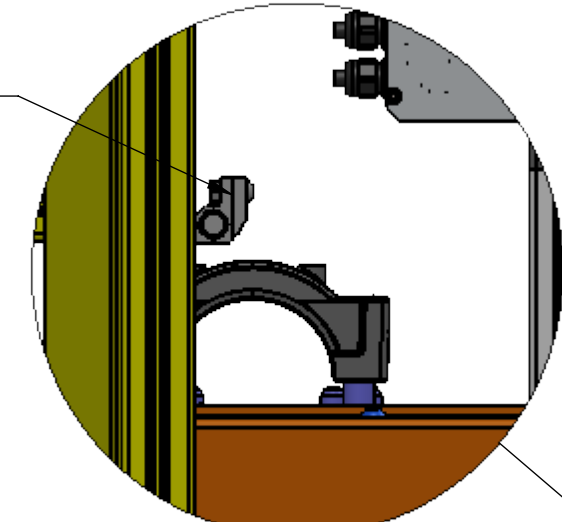

DETAIL E
SCALE 1 : 4

AIR KNIFE FOR PALLET BLOW OFF

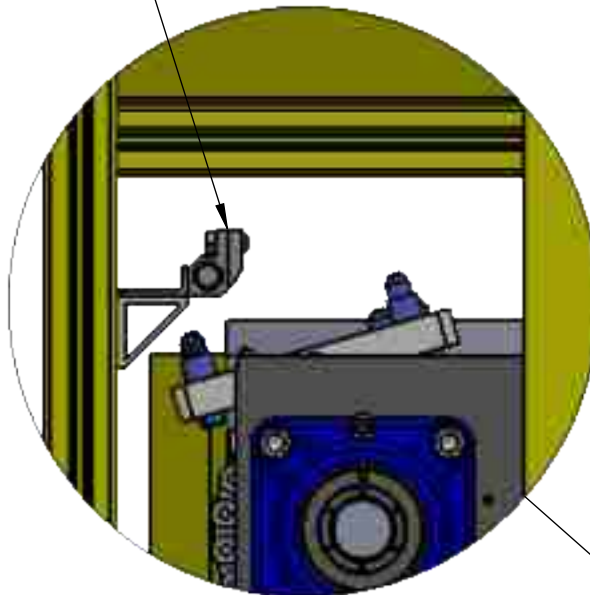

DETAIL D
SCALE 1 : 4

CONVEYOR DRIVE WITH A/B POWER FLEX4 SERIES DRIVE

NUMATICS FLEXBLOCK FRI UNIT AND BIMBA PIV60-075-075 SHUTOFF VALVE (3/4" PORTS)

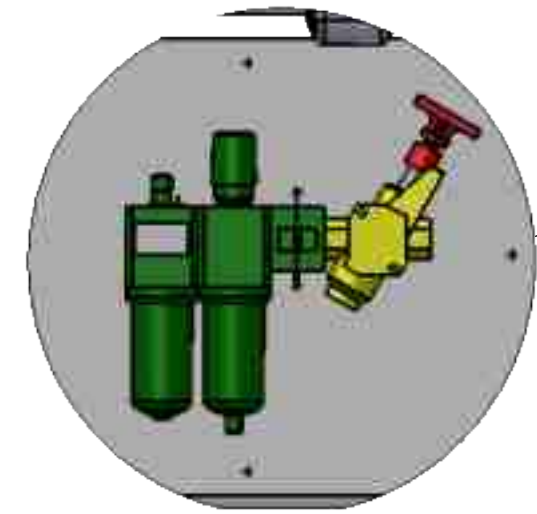

DETAIL J
SCALE 1 : 8

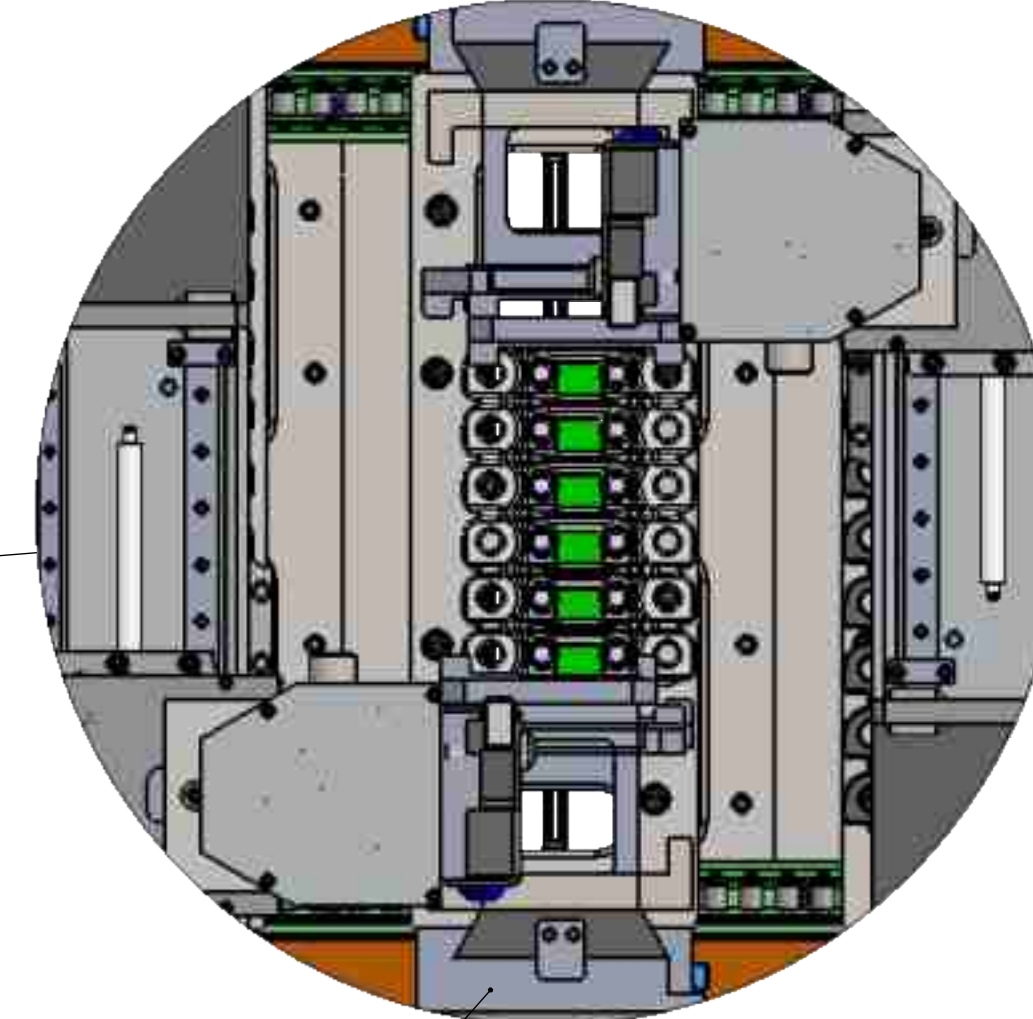
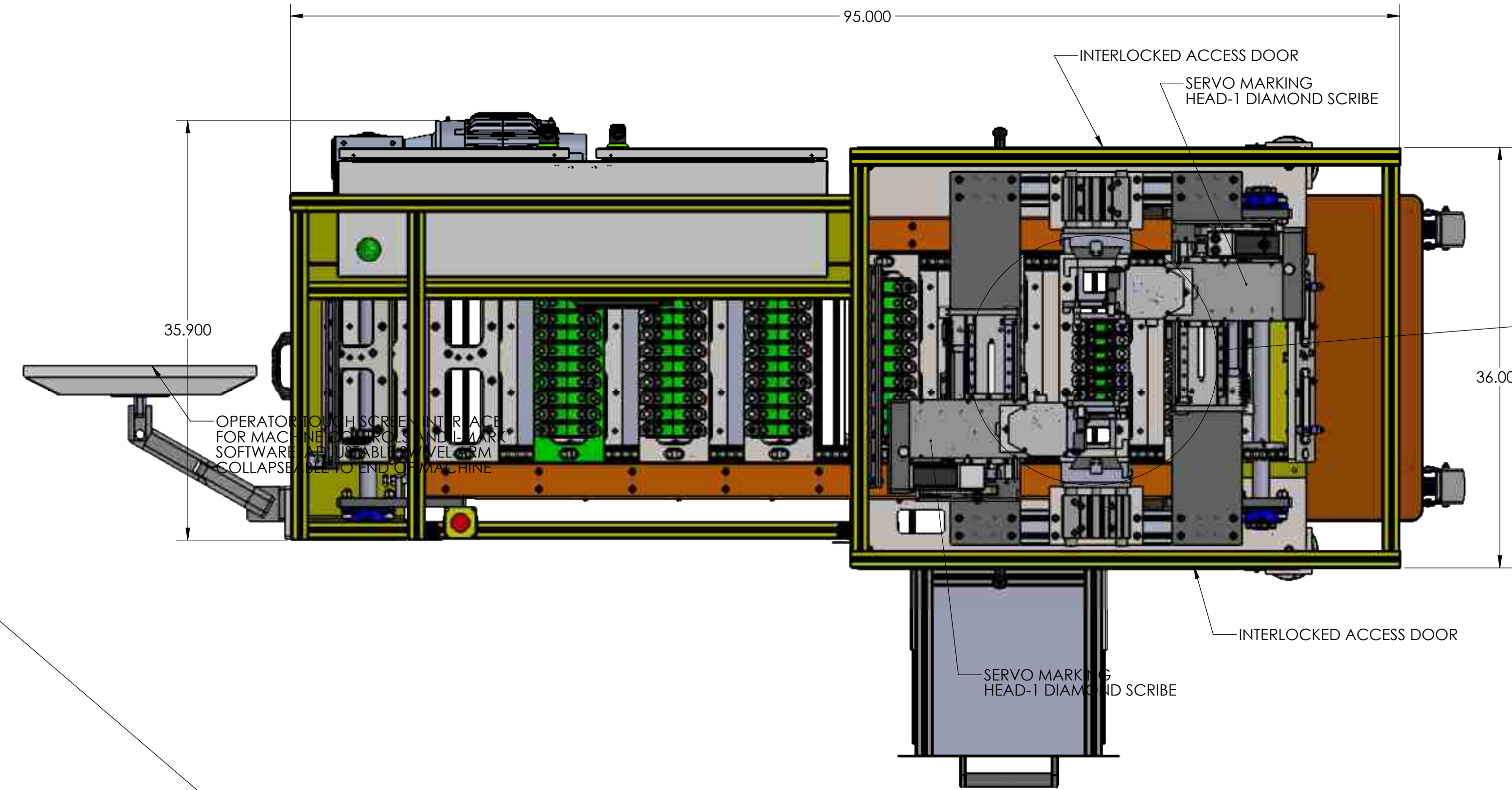

DETAIL C
SCALE 1 : 4

QUICK CHANGE PART CLAMP DETAIL FOR EACH CASTING (8) DETAILS INCLUDED WITH THIS MACHINE (1 SET FOR EACH PART)

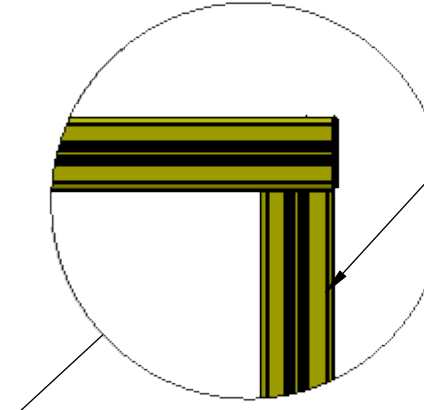

DETAIL G
SCALE 1 : 4

NOTE: MACHINE GUARDING TO HAVE .312" LEXAN GUARD PANELS AND TOP COVER ON MARKING AREA. ALL PANELS TO BE RUBBER GASKET SEALED ON (4) SIDES YELLOW TRIM ALL OUTER FACING STRUCTURE AS SHOWN

HEAVY DUTY FLOOR STYLE MACHINE BASE WITH SHEET METAL SKIRT

PIVOTING LIFT AND LOCK CASTERS

MACHINE BASE TO BE PAINTED SHILOH WHITE RAL-9016 SW=7006 EXTRA WHITE

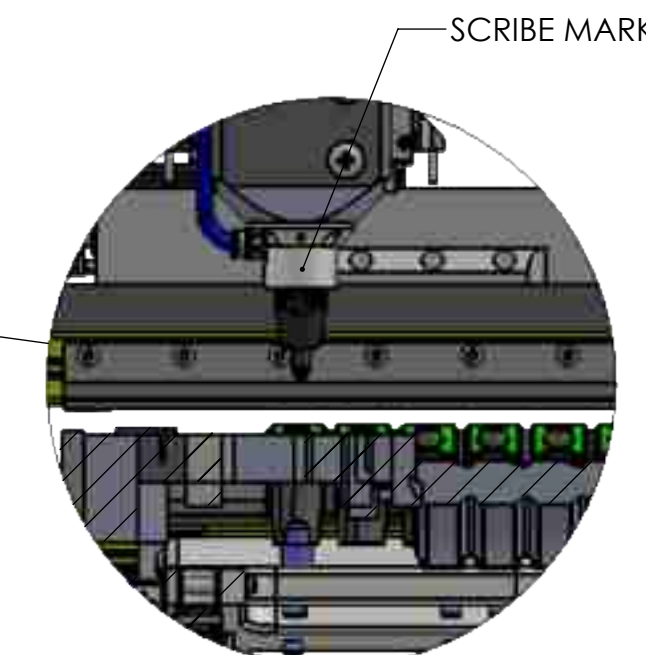
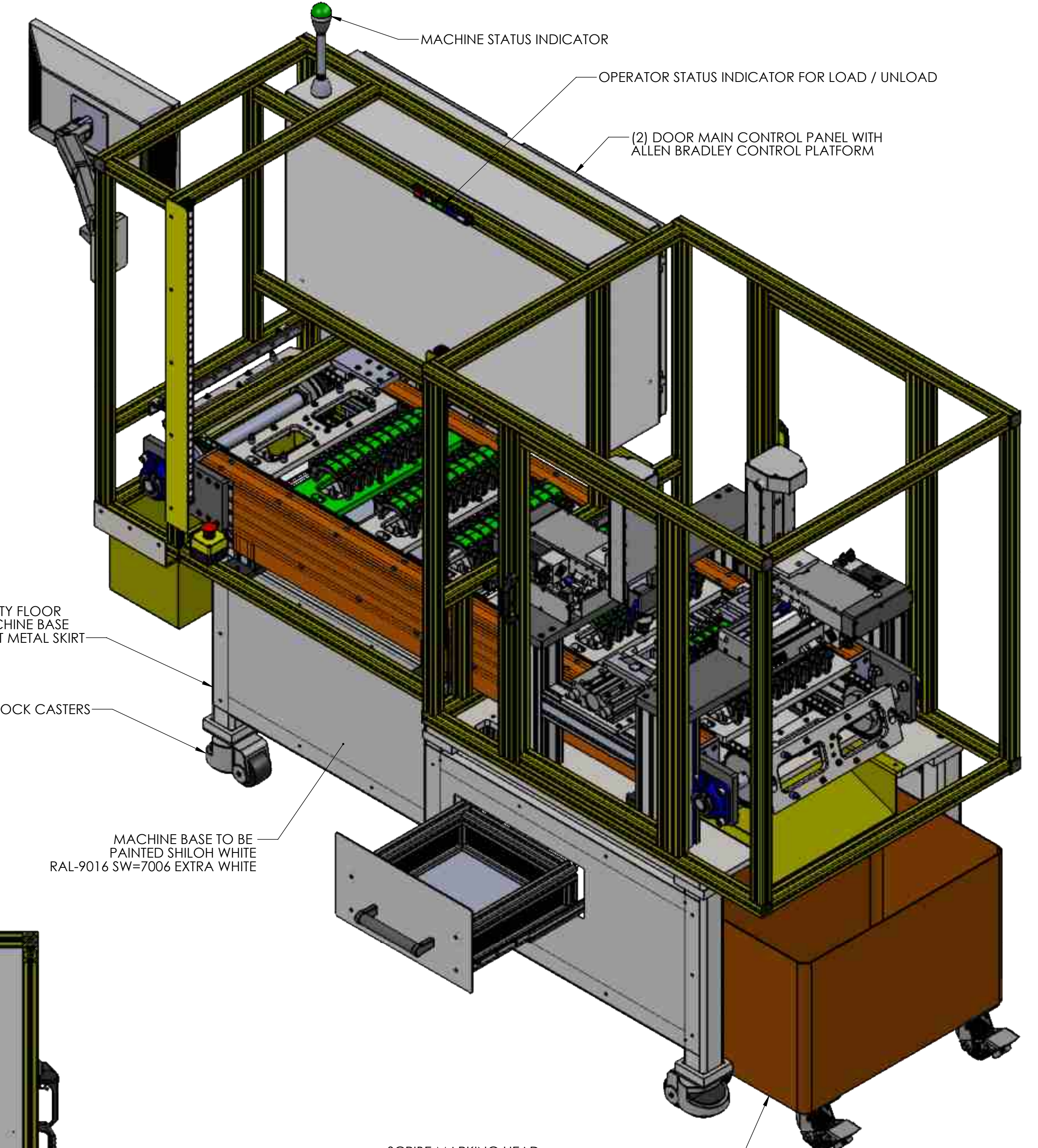

DETAIL B
SCALE 1 : 4

SCRIBE MARKING HEAD

PART STORAGE BINS WITH PIVOT LOCKING CASTERS

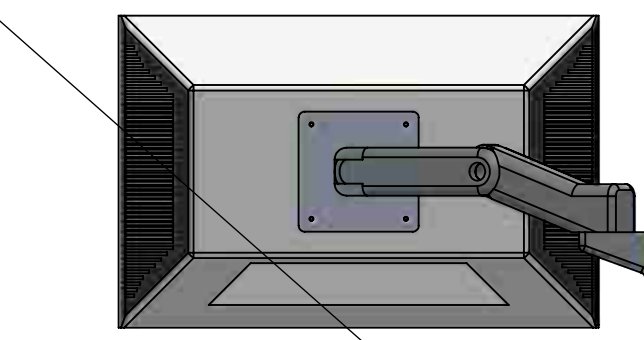

SEALED PALLET BLOW OFF AREA

REMOVEABLE DROP PAN FOR BLOW OFF DEBRIS

37.250

KEYENCE GL-R44H SERIES LIGHT CURTAIN IN SERIES WITH GL-111R SAFETY RELAY HEAVY BUMP GUARDS FOR PROTECTION

34.188 LOAD AREA

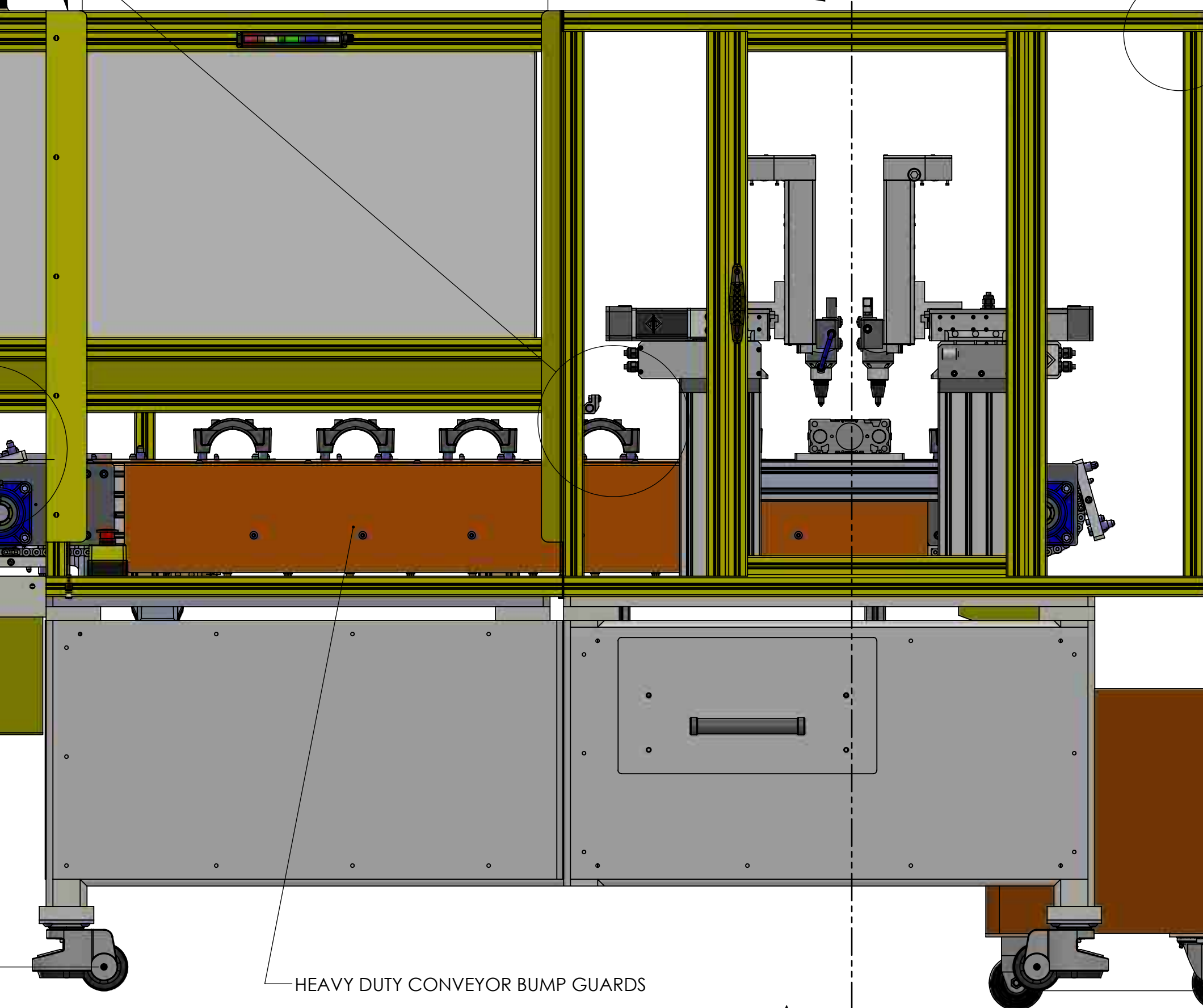

SECTION A-A
SCALE 1 : 8

ZONE	REV.	DESCRIPTION	DATE	APPROVED
A2	A	INITIAL PRINT RELEASE	09/29/17	AJH
A1	B	UPDATED HOLES IN SHEET METAL TO M6	10/12/2017	AJH

UNLESS OTHERWISE SPECIFIED:
DIMENSIONS ARE IN INCHES
TOLERANCES:
FRACTIONAL ± .003
DECIMAL ± .001
ANGULAR ± .1°
HOLE POSITION ± .010
HOLE DIA ± .003
HOLE TO HOLE ± .005
HOLE TO EDGE ± .010
HOLE TO CENTER ± .010
HOLE TO CORNER ± .010
HOLE TO SURFACE ± .010
HOLE TO HOLE ± .010
HOLE TO EDGE ± .010
HOLE TO CENTER ± .010
HOLE TO CORNER ± .010
HOLE TO SURFACE ± .010
HOLE TO HOLE ± .010
HOLE TO EDGE ± .010
HOLE TO CENTER ± .010
HOLE TO CORNER ± .010
HOLE TO SURFACE ± .010

DRAWN	AJH	DATE	08/24/17
CHECKED	AJH	DATE	08/24/17
ENG APPR			
MFG APPR			
G.A.			

PROPRIETARY AND CONFIDENTIAL
THE INFORMATION CONTAINED IN THIS DRAWING IS THE SOLE PROPERTY OF COLUMBIA MARKING TOOLS. ANY REPRODUCTION IN PART OR AS A WHOLE WITHOUT THE WRITTEN PERMISSION OF COLUMBIA MARKING TOOLS IS PROHIBITED.

AN3000 AUTOMATED CASTING MARKING SYSTEM IMC-AUTO1

SCALE: 1:10 WEIGHT: SHEET 1 OF 9